

Kegelsenker

Kegelsenker mit auswechselbaren Messern, für eine ratterfreie Bearbeitung mit grossem Senkbereich. Ausführungen als Einschneider oder Dreischneider

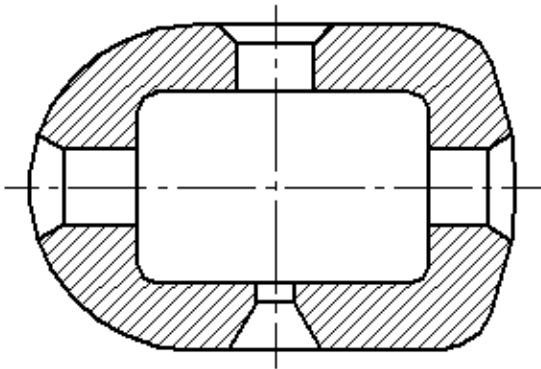

Countersinking Tool

Countersink tool with interchangeable blades. Chatter-free machining with a large countersink range. Single insert or three lip versions

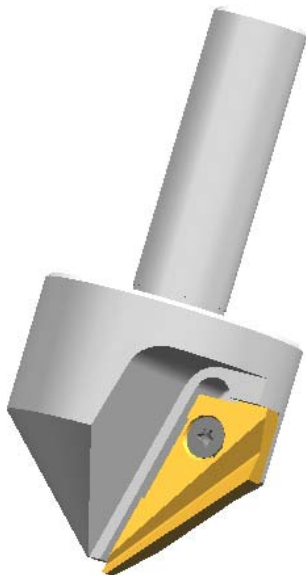

GH-K

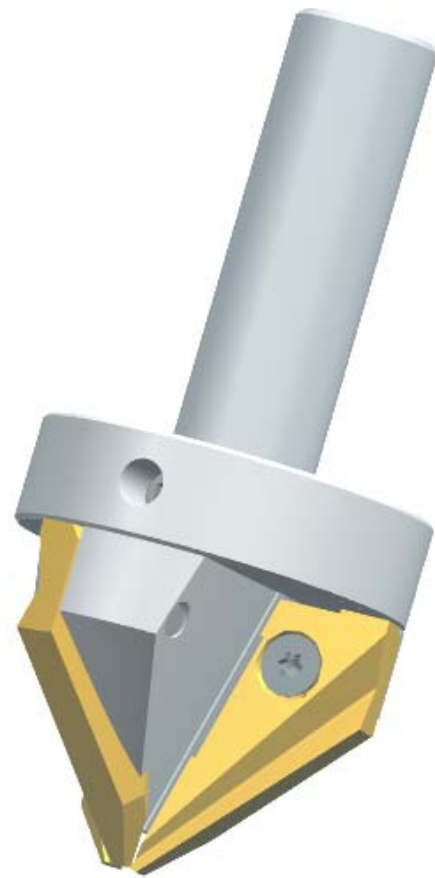

HEULE

WERKZEUG AG

CH-9436 Balgach/Switzerland

Internet www.heule.com

E-Mail info@heule.com

Phone +41 - 71 / 726 38 38

Fax +41 - 71 / 726 38 39

GH-K Werkzeuge (Dreischneider) GH-K Tools (three lips)

GH-K 25

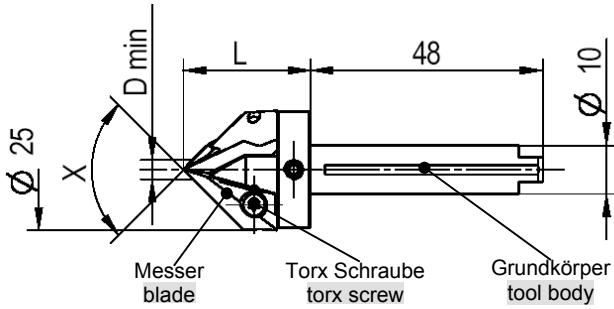

GH-K 45

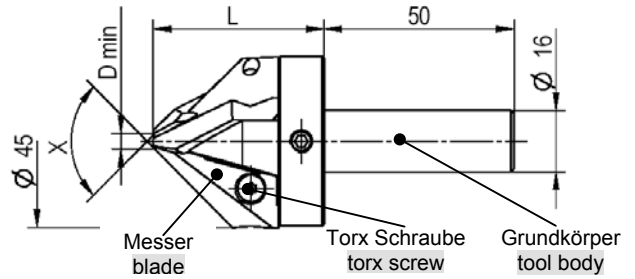

Typ series	Winkel X angle X	D min. D min.	L L	Unterlage *** shim *** GH-K-U-	Torx Schraube ** torx screw ** GH-H-S-	Schrauben- dreher torx driver GH-H-S-	Bestell-Nr. *) order No. *) GH-K-B-
GH-K 25	90°	3	26	0001	0008	2014	0001
	60°	3	34	0004	0008	2014	0601
GH-K 45	90°	4	45	0002	0009	2016	0012
	60°	9	56	0005	0009	2016	0612

*) Werkzeug ohne Messer ohne Unterlage	*) Tool without blade without shim
) Unterlage zur Schnittgeometrieänderung 0.05mm dick. Mit dieser Geometrieänderung kann das Werkzeug optimal auf unterschiedliche Materialien abgestimmt werden. Die Unterlagen werden zwischen Messer und Grundkörper eingelegt.	*) Shim to change the cutting geometry 0.05mm thick. With this geometry change you are able to tune the tool for different materials. This shims have to be placed between blade and tool body.
MK Schaft und Zoll Schaft auf Anfrage	MT shank and inch shank on request

GH-K Messer Übersicht GH-K Blades overview

Dreischneider set of three			Bestell Nr. Order No.	
Typ series	Winkel angle	Material material	unbesch. uncoated	TiN
			GH-K-M-	GH-K-M-
GH-K 25	90°	HSS-E	-----	0001
		carbide	0007	0017
	60°	HSS-E	-----	-----
		carbide	0607	0617
GH-K 45	90°	HSS-E	-----	0002
		carbide	0008	0018
	60°	HSS-E	-----	-----
		carbide	0608	0618

GH-K Werkzeuge (Einschneider) GH-K Tools (single blade design)

GH-K 25

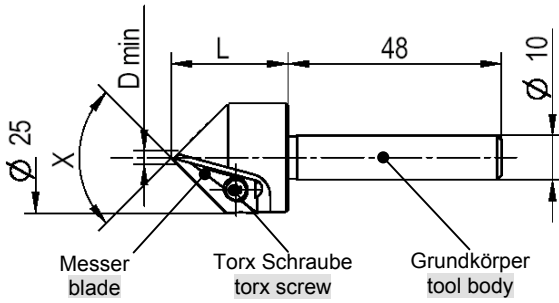

GH-K 45

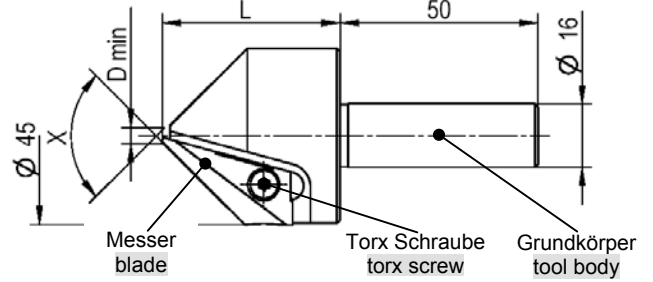

Typ	Winkel X	D min.	L	Unterlage ***)	Torx Schraube **)	Schraubendreher	Bestell-Nr. *)
series	angle X	D min.	L	shim ***)	torx screw **)	torx driver	order No. *)
				GH-K-U-	GH-H-S-	GH-H-S-	GH-K-B-
GH-K 25	90°	3	26	0007	0008	2014	0010
GH-K 45	90°	4	45	0008	0009	2016	0011

<p>*) Werkzeug ohne Messer ohne Unterlage</p> <p>***) Unterlage zur Schnittgeometrieänderung 0.05mm dick. Mit dieser Geometrieänderung kann das Werkzeug optimal auf unterschiedliche Materialien abgestimmt werden. Die Unterlagen werden zwischen Messer und Grundkörper eingelegt.</p>	<p>*) Tool without blade without shim</p> <p>***) Shim to change the cutting geometry 0.05mm thick. With this geometry change you are able to tune the tool for different materials. The shims have to be placed between blade and tool body.</p>
<p>***) Den Einschneider nur mit automatischem Vorschub und stabiler Spindel sowie guter Werkstückaufspannung einsetzen.</p>	<p>***) Use the single blade design only with power feed and stable spindle as well as with a ridge set up.</p>

GH-K Messer Übersicht GH-K Blades overview

Einschneider			Bestell Nr.	
single bladed			Order No.	
Typ	Winkel	Material	unbesch.	TiN
series	angle	material	uncoated	TiN
			GH-K-M-	GH-K-M-
GH-K 25	90°	HSS-E	-----	0022
		carbide	0023	0024
GH-K 45	90°	HSS-E	-----	0028
		carbide	0029	0030

GH-K Kegelsenker

GH-K Countersinking Tool

- Grosser Senkbereich von Ø 3mm bis Ø 45mm
- Ratterfreies Arbeiten
- Für Zirkularfräsen geeignet
- Messer in Hartmetall und HSS-E
- Messer nachschärfbar
- alle Beschichtungen möglich
- Universell einsetzbar
- Optional mit Kühlmittelzuführung
- Unterlagen zur Schnittgeometrie-änderung für aggressiveres Schnittverhalten

- Large countersink range from Ø 3mm up to Ø 45mm
- Chatter-free machining
- Circular milling is possible
- Inserts in solid carbide and HSS-E
- Re-grindable inserts
- all coatings possible
- Universal useable
- Optional with through coolant
- Shim to change the clearance geometry for a more aggressive cutting



Zirkularfräsen
Circular milling

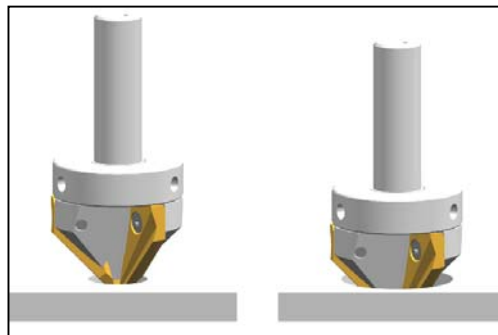

Grosser Senkbereich
Large countersink range

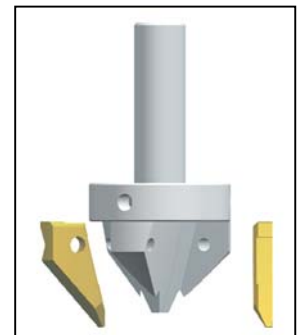

Messer auswechselbar
Interchangeable blades

HEULE WERKZEUG AG

CH-9436 Balgach/Switzerland

USA:

HEULE TOOL CORPORATION

4722A Interstate Drive
Cincinnati, Ohio 45246 / USA

GB:

HEULE TOOL UK LTD

1 Beacon Close / Groby
LE60GB Leicester
Great Britain

Telephone +41-71 726 38 38
Telefax +41-71 726 38 39
Internet www.heule.com
E-Mail info@heule.com

Telephone +1 (513) 860 99 00
Telefax +1 (513) 860 99 92
Internet www.heuletool.com
E-Mail usa@heule.com

Telephone +44(0)116 287 9062
Telefax +44(0)116 287 1321
Internet www.heule.com
E-Mail heuleuk@heule.com

Vertreten durch:
Represented by: